

# AquaSmart

## MODEL 7610 ADVANCED MICROPROCESSOR BOILER CONTROL

### DESCRIPTION / APPLICATIONS

The Beckett AquaSmart 7610 advanced boiler control is a UL limit-rated control designed for use on residential and light commercial hot water boiler systems. All models include the Beckett HeatManager™ dynamic temperature logic, which meets DOE 2012 reset requirements and can provide up to 20% savings in fuel consumption. Wireless Outdoor Temperature Reset can be added using the Wireless Temperature Module and the remote temperature sensor. The backlit LCD digital display provides LWCO status and the touch pad allows programming of the temperature limits, differentials, and circulator control. The 7610 can be used with Beckett dual Temperature/LWCO sensors to provide both temperature control and low water cutoff functionality. The 7610 can also be used with Beckett Temperature Only sensors to provide temperature control without the low water cutoff function.



# Beckett

# Table of Contents

<b>Technical Specifications</b> .....	4
Electrical Ratings .....	4
Temperature Ranges and Differentials .....	4
Environmental Ratings .....	4
Approvals .....	4
<b>How to Use this Manual</b> .....	6
<b>Installation</b> .....	6
New Installations or Replacement Controls .....	6
Replacing an Existing Control .....	6
Installing the Immersion Well .....	7
Mounting the 7610 Control .....	7
<b>Wiring</b> .....	8
Wiring the 7610 Control .....	9
Thermostat Wiring .....	9
Damper Connection .....	9
<b>Installing the Temperature Only Sensor</b> .....	10
<b>Installing the Temperature/LWCO Sensor</b> .....	12
Connecting the Green LWCO Circuit Completion Wire .....	14
<b>AquaSmart Navigation Guide</b> .....	15
<b>Set Up and Programming</b> .....	16
7610 Start Up .....	16
<b>Programming Basic Functions</b> .....	17
A. Set High Limit Temperature .....	17
B. Set Low Limit Temperature .....	17
C. Set High Limit Differential .....	18
D. Set Low Limit Differential .....	18
How a Boiler Control Works .....	19
<b>Additional Programming Options</b> .....	20
Heat Manager .....	20
A. Changing the Heat Manager Settings .....	20
B. Viewing the Cycle History .....	20
C. Changing the Circulator Settings .....	21
D. Changing Domestic Hot Water Priority (DHWP) Setting .....	22
E. Selecting Fahrenheit or Celsius Temperature Display .....	22
F. Changing Low Water Cutoff (LWCO) Settings .....	22
G. Wireless Outdoor Reset Menu .....	23
<b>Start Up and Checkout</b> .....	24
New Boiler Installation - Checklist .....	24
Replacement Control Installation .....	24
Control Checkout Procedure .....	24
Low Water Cutoff Test Procedure .....	26
<b>7610 Operation</b> .....	26
<b>7610 Status Messages</b> .....	27
Freeze Resistance .....	28
<b>Diagnostics and Troubleshooting</b> .....	28
Lockout Messages .....	28
Temporary Stop .....	29
Troubleshooting .....	30
Additional Diagnostic Information - History .....	31
Record History Here .....	32
<b>Final Checklist</b> .....	33
<b>Service</b> .....	33
<b>Appendix</b> .....	34-37
<b>Limited Warranty Information</b> .....	40

## 7610 Features

- HeatManager™ dynamic temperature reset for energy savings
- — DOE 2012 Compliant
- — Meets NR CAN 2012 Requirements
- Advanced microprocessor-based design
- Backlit LCD digital display with LWCO status and touch pad buttons for programming
- Adjustable High and Low limit settings and separate High and Low differentials settings to better customize system operation
- Easier to wire with expanded wiring enclosure
- Circulator control - 120Vac
- Programmable domestic hot water priority when using indirect or storage type water heaters
- Replaces most standard boiler temperature controls using temperature only sensor
- Redesigned Temperature/LWCO combination sensor provides reliable temperature control and Low Water Cutoff compliance
- Improved LWCO circuit connections
- Programmable circulator-on and -off delays
- Helps prevent freeze-up by energizing circulator and ZC if an error condition is detected
- Provides Outdoor Temperature Reset when used with optional 7600WTMU
- Compatible with cold-start boilers
- 6-pin vent damper receptacle on 7610B for easy wiring to most 24 volt vent dampers

### **WARNING**

**Do not use 7610 controls or sensors in steam boiler applications, pools, spas, hot tubs or wall mounted combi-boilers. For use in hot water boilers or water heaters only. Do not use in unapproved applications or applications that exceed the listed specifications.**

### **WARNING**

#### **Electrical Shock, Fire, Explosion and Burn Hazards**

*This control must be installed, adjusted and put into operation only by a trained, licensed, qualified professional or service agency in accordance with the National Electric Code ANSI/NFPA 70 (Canada CSA C22.1) state, local codes and authorities having jurisdiction.*

- The installer must carefully read and follow the installation and service instructions contained in this manual and make them available to the equipment owner, so they can be kept for future reference.
- This product is not to be used as a step or a shelf.

### **WARNING**

#### **Electrical Shock Hazard**

*The 7610 control should only be operated with the door closed and secured by the locking screw.*

**Figure 1 – Getting to know the 7610 Series Control**



## Technical Specifications



**Do Not Use This Control in an Application that is Not Within the Ratings Listed in This Section. Improper Control Operation May Result.**

### Electrical Ratings

Input Voltage: 120 Vac - 60 Hz.  
 Input Current: 0.1 A + B1 + C1 + ZC  
 MAX Input Current: 20A (Reduce to 15A if optional power disconnect switch is used)  
 24 Vac Thermostat Anticipator Current: 0.1 Amp.  
 Burner Current Rating (B1):  
 7610A (oil): 7.4 A at 120 Vac FLA; 44.4 A inrush LRA.  
 7610B (gas): 1.25 A at 24 Vac; 30 VA (total load).  
 Circulator Current Rating (C1): 7.4 A at 120 Vac FLA; 44.4 A inrush LRA.  
 Zone Control Current Rating (ZC): 7.4 A at 120 Vac FLA; 44.4 A inrush LRA.

### Temperature Ranges and Differentials

- High Limit Setting Range: 100° to 220°F (37° to 104°C).
- High Limit Differential Range: 5° to 45°F (2° to 25°C).
- Low Limit Setting Range: 100° to 205°F (37° to 96°C).

- Low Limit Differential Range: 10° to 45°F (5° to 25°C).
- Factory Range Stops available - consult factory.
- Temperature/LWCO Sensors: Storage -40°F to +150°F (-40°C to +65°C). Operating Range: 32°F to 250°F (0° to 121°C).
- Temperature Sensor Time Constant: 40 seconds.

### Environmental Ratings

- Storage Temperature: -40° to +150°F (-40° to +65°C).
- Operating Temperature: -4° to +150°F (-20° to +65°C).
- Maximum Sensing Element Temperature: 250°F (121°C).
- Relative Humidity: 5 to 85% RH, non-condensing and non-crystallizing.

### Approvals



Underwriters Laboratories Listed to UL353, UL1998 for U.S. and Canada; CSA C22.2 No. 24



**Figure 2 – Basic Dimensions (inches)**

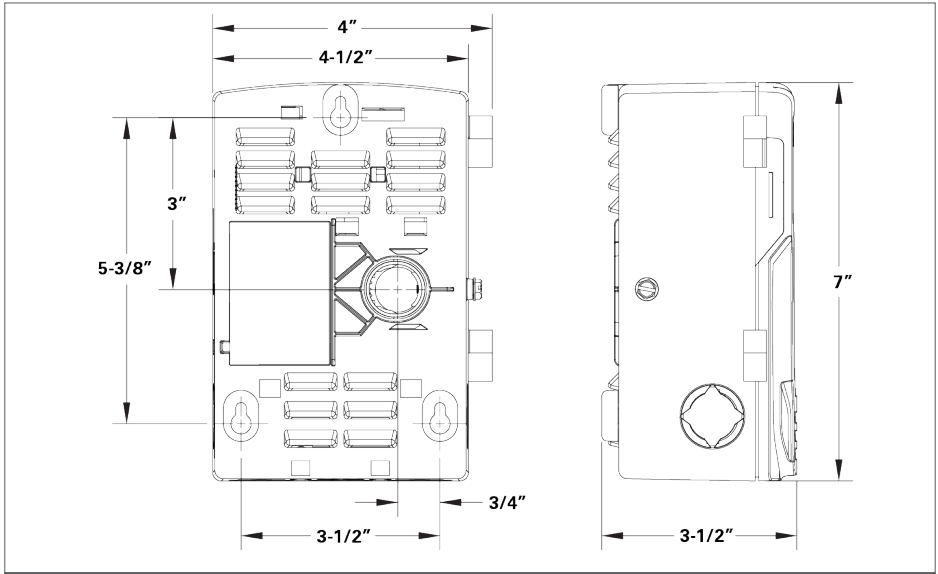

**Table 1 – AquaSmart 7610**

Part #	Description
7610A	AquaSmart Boiler Control - 120 volt AC burner circuit
7610B	AquaSmart Boiler Control - 24 volt AC burner circuit
7622TW	Immersion Well - 3/4" NPT thread - see table below for insulation and insertion depth
7600P / 7630P	Temperature and low water cutoff sensor - must be used with Beckett immersion well
7600TS / 7640TS	Temperature only sensor - can be used with standard immersion wells
7600RMU	48" sensor cable extension and coupler, mounting template, mounting screws, cable tie
7600WTMU	Optional module and wireless sensor for outdoor reset

**Figure 3 – Immersion Well Overall Dimensions & Specifications**

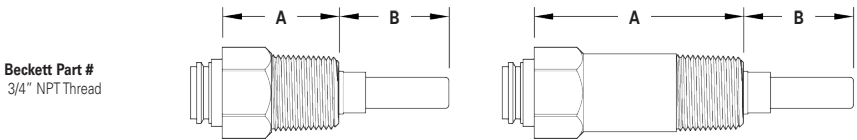

Part No.	A Insulation Depth	B Insertion Depth
7622TW01	2-3/16"	7/8"
7622TW02	2-3/16"	1-5/8"
7622TW03	3-1/2"	1-5w/8"
7622TW04	4-3/4"	1-5/8"

Specifications	
Storage Temperature Range	-40° to +250°F
Operating Temperature Range	32° to 250°F
Maximum Pressure	250 PSIG
Installation Torque Range (Screw-In)	60 Ft/lbs.

**WARNING****Burn, Scald, Explosion, and Equipment Malfunction Hazard**

*Installation or replacement of the controls covered in this manual must be done only by a qualified service agency or technician who is trained and experienced in the use of boiler controls.*

The installing technician must read and follow all warnings and instructions in this manual and the instructions provided by the manufacturer of the control being replaced.

## Installation

### New Installations or Replacement Controls

Make sure the immersion well matches the requirements for size and insertion length specified by the boiler manufacturer. See **Figure 3** on page 5 for available Beckett immersion well sizes.

For temperature only applications use the 7600TS / 7640TS temperature only sensor and a Beckett immersion well or a standard brass/copper well matching the insulation depth and insertion length recommended by the boiler manufacturer.

If temperature control and low water cutoff functions are needed, use the Beckett 7600P / 7630P dual Temperature/LWCO sensor. Use the Beckett well matching the boiler manufacturers recommendations for insulation depth and insertion length.

A matching Beckett well must be used to provide the LWCO function. The Beckett 7600P / 7630P dual Temperature/LWCO sensor will not function properly in a standard immersion well or other LWCO wells. If using the 7600P / 7630P combination temperature/LWCO sensor in a non-Beckett immersion well, we recommend turning off the LWCO function. (See "F. Changing Low Water Cutoff (LWCO) Settings" on page 22). If the Low Water Cutoff function is required, install a Beckett immersion well or install a separate LWCO control.

See **Figure 3** on page 5 for available Beckett immersion well sizes.

### Replacing an Existing Control

**WARNING****Electrical shock hazard.**

*Disconnect all electrical power to the appliance circuit before replacing the control. There may be more than one disconnect switch.*

1. Note the temperature settings for high limit, low limit, and differentials, then disconnect power to the control.
2. Check the existing wiring to the control for any damage. Replace any damaged wires. Check the position of each wire on the control and compare to wiring diagrams on appliance or control.
3. Label each wire to help with accurate re-connection.
4. Remove each wire from the old control. Make sure each label is intact.
5. Loosen the control mounting arrangement and remove the control from the appliance.

## How to Use this Manual

The installing technician must read and follow all warnings and instructions in this manual as well as the instructions provided by the manufacturer of the boiler or the control being replaced.

After reading the warnings and instructions, choose the section of the manual for the task to be done.

### ■ Installation - new and retrofit

- ▶ Replacing an Existing Control (Pg. 6)
- ▶ Installing the Well (Pg. 7)
- ▶ Mounting the 7610 control (Pg. 7)
- ▶ Wiring the 7610 Control (Pg. 9)
- ▶ Installing the Temperature Only Sensor (Pg. 10)
- ▶ Installing the Temp/LWCO Sensor (Pg. 12)

### ■ Set Up and Programming

- ▶ Programming Basic Functions (Pg. 17)
- ▶ High limit (Pg. 17)
- ▶ Low limit (Pg. 17)
- ▶ High and Low Limit Differentials (Pg. 18)

### ■ Additional Programming Options (Pg. 20)

- ▶ Heat Manager (Pg. 20)
- ▶ Circulator Settings (Pg. 21)
- ▶ Domestic Hot Water Priority (Pg. 21)
- ▶ Selecting Fahrenheit or Celsius (Pg. 22)
- ▶ Low Water Cutoff Settings (Pg. 22)

### ■ Start Up and Checkout

- ▶ New Boiler Installation (Pg. 24)
- ▶ Replacement Control Installation (Pg. 24)
- ▶ Control Checkout Procedure (Pg. 24)
- ▶ Low Water Cutoff Test Procedure (Pg. 26)

### ■ 7610 Operation (Pg. 26)

### ■ 7610 Status Messages (Pg. 27)

- ▶ Freeze Resistance (Freeze Res) (Pg. 28)

### ■ Diagnostics - Troubleshooting

- ▶ Lockout Messages (Pg. 28)
- ▶ Temporary Stop (Pg. 29)
- ▶ Troubleshooting (Pg. 30)
- ▶ Additional Diagnostic Information - History (Pg. 31)

## NOTICE

Differential settings are used differently on non-Beckett controls. Consult the manual of the control being replaced for information on differentials.

recommended by the boiler manufacturer.

- When adding pipe sealant to the threads of the Beckett 7622TW thermowell, only use sealant approved for brass. **DO NOT USE TEFLON TAPE ON BRASS WELLS IN LWCO APPLICATIONS.** Avoid getting sealant on the insulating sleeve around the copper tube.
- Tighten well with open end or box wrench. Must be leak free (torque requirement — *brass well*: 60 ft./lbs. max). **DO NOT ATTEMPT TO CLAMP DOWN ON OR TIGHTEN BLACK INSULATOR OF WELL. DOING SO MAY RESULT IN LEAKS.**

Figure 4 – Mounting Options

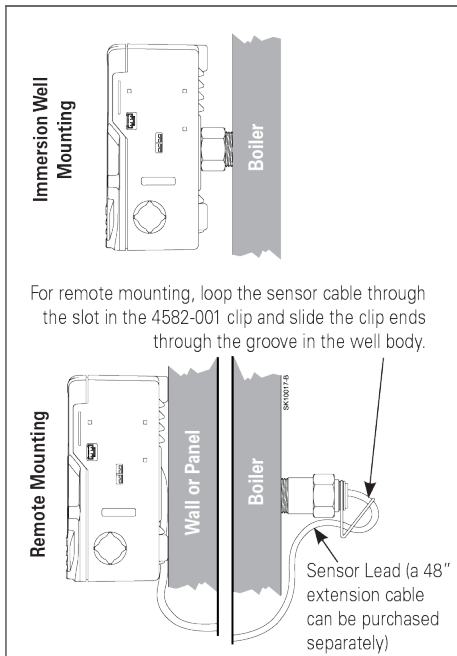

For remote mounting, loop the sensor cable through the slot in the 4582-001 clip and slide the clip ends through the groove in the well body.

## Mounting the 7610 Control

**OEM Installation:** When replacing an OEM-installed AquaSmart, consult the appliance manufacturer's wiring diagrams and instructions for additional information.

**Retrofit Installation:** The 7610 can be used to replace most standard boiler temperature controls. Use the 7600TS / 7640TS temperature only sensor when using a standard copper/brass well. Use the Beckett 7600P / 7630P Temperature / LWCO combination sensor and a matching Beckett well for low water cutoff applications.

The two basic methods for mounting the 7610 to a boiler are shown in **Figure 4**.

- Immersion Well Mounting** – This is the most common method for mounting the control. If the existing well is not suitable for any reason, replace the well (see instructions above).
- Remote Mounting** – The 7610 is designed to provide a remote mounting option. The mounting base has clearance built-in to allow the temperature sensor lead to exit through the 7/8" hole in the back of the control. A remote mounting kit (Pt. No. 7600RMU) that includes a 48" extension cable and mounting screws can be purchased separately for applications where additional cable length is needed.

(Refer back to **Figure 4** for appropriate mounting method).

### Mounting to the Immersion Well:

- The AquaSmart Sensor may be installed in the well before or after mounting the control. See *Installing the Temperature Sensor* or *Installing the Temperature/LWCO Sensor*. Thread the sensor cable and pushrod through the well mounting hole.
- Loosen the well bracket screw on the left hand side of the control, and make sure sliding metal bracket is clear of the mounting hole. Make

## Installing the Immersion Well

**A matching Beckett well must be used to provide the LWCO function!**

### Using an existing well:

- Make sure the immersion well is clean and dry inside with no leaks or dents that would prevent insertion of the new sensor.
- If unsure of well condition or if deposit build up on the well is suspected, replace with a new well.

### Installing a new well:

- Allow any water in the boiler to cool and drain below well level before replacing an existing well.**
- Make sure the threads in the boiler tapping are clean.
- The new immersion well must match the insulation depth and the insertion length

sure that the well is properly mounted in the boiler.

3. Holding the control upright, align the 7/8" diameter hole on the back of the control with the immersion well. Insert the left edge of the well into the mounting hole first. Position the control upright and tighten down the #10 well bracket screw located on the left side of the control. Tighten until the control is straight and held securely in place. See **Figure 5**.

**Figure 5 – Mounting to Immersion Well**

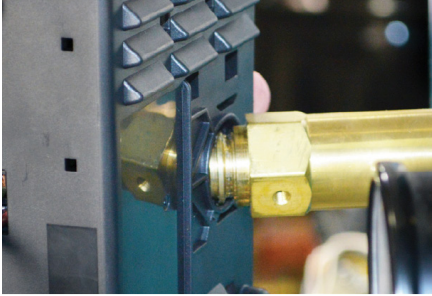

### Mounting to Wall or Appliance Panel:

1. Use the AquaSmart mounting template to locate the mounting holes in the desired location on the mounting surface. The template can be found in the back of this manual. Make sure the mounting screw placement will not cause any damage to the appliance or other components.
2. Use (3) #8 x 3/4" self drilling screws (7/64" hole diameter if pre-drilling) included in the installation kit. Run screws into mounting surface, leaving a 1/4" space between bottom of screw head and mounting surface.
3. Open the cover of the 7610. If the sensor connection will be made through the well mounting hole on the back side of the case, thread the sensor cable through the well mounting hole and connect the sensor to the jack on the underside of the display. (see "Installing the Immersion Well" on page 7) If necessary, use the 48" cable extension (Part No. 51210) to connect the sensor to the control.
4. Locate the three keyhole locations in the plastic case. Align keyholes over the mounting screws and secure the control by tightening the screws.

## Wiring

### **⚠ WARNING**

#### **Electrical Shock, Fire, Explosion and Burn Hazards**

*This control must be installed, adjusted and put into operation only by a trained, licensed, qualified professional or service agency in accordance with the latest revision of the National Electric Code ANSI/NFPA 70 (Canada CSA C22.1) state, local codes and authorities having jurisdiction.*

- Follow the appliance manufacturer's wiring diagrams and note all safety controls.
- Typical safety controls include high temperature or pressure limits, low water cutoffs, anti-scald valves, pressure relief valves and water feed valves.
- Verify all limits and safety controls are installed and functioning correctly, as specified by the appliance manufacturer, applicable safety standards, codes and all authorities having jurisdiction.
- Provide ground wiring to the appliance, burner and controls.

### **⚠ WARNING**

#### **Electrical Shock Hazard. Can Cause Severe Injury, Death, or Equipment Damage.**

*Disconnect power before wiring to prevent electrical shock or equipment damage.*

- All wiring must comply with local electrical codes and ordinances. The limits given in the specifications section must not be exceeded when applying this control. Terminals on the 7610 are approved for copper wire only.
- Refer to the label on the inside of the 7610 door or to Technical Specifications in this manual for Electrical ratings and maximum load information. Use manufacturer instructions when wiring controlled equipment or refer to typical hookups in **Figure 21** through **Figure 24**.
- More than one service switch may be needed to disconnect all power to the 7610. The optional power disconnect switch interrupts power to the 7610 burner circuit. *Some terminals and connections like ZR and the input to the optional power disconnect switch will still be live.*

### **⚠ WARNING**

#### **Explosion Hazard. Can Cause Severe Injury, Death or Property Damage.**

Use this product only in systems with a pressure relief valve.



## Wiring the 7610 Control

- Disconnect all power to the appliance before starting the wiring process.
- Consult the appliance wiring diagrams to check the manufacturer's wiring configuration/specifications.
- If replacing an existing control, use the wire labels applied during control removal to guide placement of the wires on the 7610 terminals.
- Refer to the Appendix for some typical wiring diagrams.
- Verify the wires are labeled correctly and make connections to the appropriate terminals on the 7610 control wiring terminal strip.
- Provide the required disconnect means and overload protection on the power supply.
- Connect control conduit bracket to earth ground using the supplied grounding screws.
- B1 terminal is a 1/4" male quick connect terminal.

## Wiring Diagrams

The wiring diagrams provided in this manual are examples of typical wiring. The wiring provided by the appliance manufacturer should be followed where possible. Additional wiring diagram examples are available in the Beckett publication "Guide to Energy Savings" part # 61856. This publication is available on line at [beckettcorp.com](http://beckettcorp.com) or through your local Beckett Distributor.

When wiring is completed, move to "Installing the Temperature Only Sensor" on page 10 or "Installing the Temperature/LWCO Sensor" on page 12.

## Thermostat Wiring

Some Thermostats Are Polarity Sensitive. Reversed polarity could cause erratic cycling of the boiler control.

- Connect the red thermostat wire (from the RH or R terminal of the thermostat) to the TR terminal on the control.
- Connect the white thermostat wire (from the W terminal of the thermostat) to the TW terminal on the control.

### NOTICE

**7610B only:** TERMINALS TR (Z or hot) and B2 (TV or ground) offer a 24-volt supply for operating auxiliary 24 VAC components on the boiler.

**IMPORTANT: To prevent damage to the control, do not exceed 30 VA in total load on the thermostat and the burner circuits combined.**

**How to calculate VA** - Add all AMP ratings of 24VAC components in this circuit and multiply sum by 24 volts. (Example:  $0.4 + 0.4 + 0.2 + 0.2 = 1.2A \times 24V = 28.8VA$ )

### CAUTION

7610B only: When using the 7610B to replace an existing control, the existing control may have used an external transformer for operating other 24 VAC equipment. The 7610B internal transformer provides 30 VA for external components. If external transformers are still needed, proper polarity of the transformer secondaries must be maintained. Failure to properly connect transformer secondaries may result in shorting or damage to the appliance, control or transformers. **Figure 23** provides an examples of proper transformer wiring.

### NOTICE

When powering multiple circulators from the C1 and C2 terminals, do not exceed the circulator output rating. If the sum of the full load amps of all the circulators exceeds 7.4 A, use the C1 and C2 terminals to power the coil of an installer supplied contactor. Use the contacts of the contactor to switch L1 power to the circulators.

### NOTICE

Observe proper polarity when wiring L1 and L2. If polarity is reversed, a call for heat on the ZR input may not be recognized.

## Damper Connection

### NOTICE

To wire a vent damper to the 7610B, first remove jumper plug from 6-position receptacle and then connect 6-pin connector of the vent damper to the receptacle. See **Figure 6**. Once the 7610B is operated with a vent damper, the control will not work without a damper connected (even if the jumper plug is replaced). When a 7610B is operated for the first time with a vent damper, an internal fuse will blow. This may create an audible pop and a small amount of smoke. This does not indicate a problem with the control.

Figure 6 – Vent Damper Connections

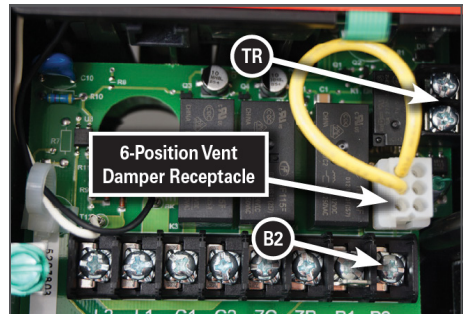

**Figure 7 – Installation of Temperature Only Sensor in Standard Brass/Copper Immersion Well**

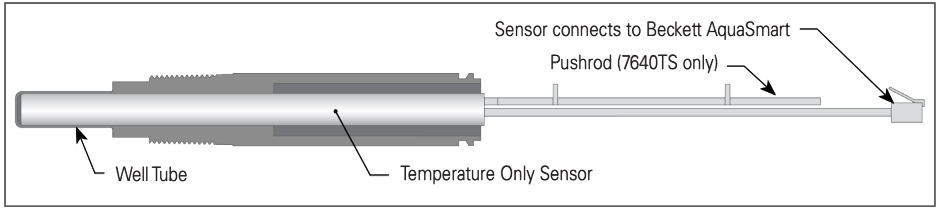

## Installing the Temperature Only Sensor

Proper installation of the sensor and well is critical for safe and accurate control operation!

No LWCO function will be provided with this sensor. LWCO: NA will show on the status screen when a temperature only sensor is used. The 7600TS/7640TS temperature only sensor can be used to provide high limit, low limit and circulator operation in standard wells or Beckett immersion wells. This sensor provides temperature control only, no low water cutoff function.

1. Make sure the immersion well is clean and dry inside, has no leaks, is of proper length and has no dents that would prevent proper insertion of the new sensor.
2. If unsure of the well condition or if deposit build up is suspected, replace the well. See Installing the Well.
3. With power to the control off, insert the sensor into the well. Grasp the pushrod and/or sensor lead and push forward until the sensor is fully inserted into the well as in **Figure 8**. The sensor must be fully inserted for proper temperature sensing.
4. For the 7640TS, once the sensor is fully inserted, cut the push rod as shown in **Figure 9** to match the well insertion lengths listed in **Table 2**. For well mount applications, choose the disc furthest out on the pushrod that will still allow the door to close completely. No trimming is needed for 4-3/4" wells. Do not cut or damage sensor lead wires.
5. Insert the telephone type sensor connector into the plug on the display as shown in **Figure 11**.
6. If the control is mounted remotely, additional sensor cable length may be needed to reach the sensor plug-in on the control. Use the extension cable (part no. 52120), found in the 7600RMU Remote Mount Kit, to extend the lead by 48".
7. For remote mount installations, install sensor retaining clip (Part No. 4582-001) as shown in **Figure 12**. Place cable between groove in the clip and attach clip into groove of immersion well. This anchors the sensor securely inside the immersion well. On remote mount applications, clipping the pushrod is still recommended.

### NOTICE

The Temperature Only and Temperature/LWCO sensors are not tested or approved for strap-on or surface mounting to the outside of a pipe. They are for use in immersion wells only.

**Table 2 – Sizing 7630P / 7640TS Sensor Pushrod to Well Insertion Length**

Beckett Brass Wells		
Beckett #	Well Size	Cut Behind
7622TW01	2-3/16" insulation, 7/8" insertion	Disc 1
7622TW02	2-3/16" insulation, 1-5/8" insertion	Disc 2
7622TW03	3-1/2" insulation, 1-5/8" insertion	Disc 3
7622TW04	4-3/4" insulation, 1-5/8" insertion	No Cut

- For remote mount applications, cut the pushrod behind the first disc outside of the well.
- Non-Beckett wells may have different depths, cut pushrod to a length that allows the door to close properly.
- The sensor is not tested or approved for pipe-mount installation. **It is for use with immersion wells only.**

### NOTICE

The inside of the well must be dry before installing sensor. Moisture in the well could lead to premature failure.

**WARNING**

**Burn and Scald Hazard**

*Excessive water temperatures could cause explosion, burns, scalding, pressure relief flooding and fitting leaks.*

- Carefully follow the outlined procedures for temperature sensor installation to ensure accurate water temperature sensing and effective control operation.
- Make sure the plumbing for domestic hot water has anti-scald valve protection.

**Figure 8 – Inserting Sensor in Well**



**Figure 9 – Clipping the Pushrod to Length**



**Figure 10 – Installation of Temperature/ LWCO Sensor**

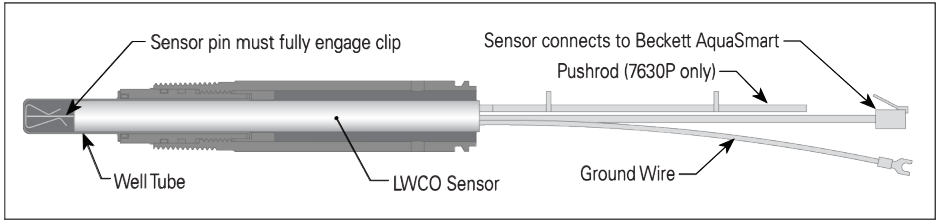

## Installing the Temperature/ LWCO Sensor

Proper installation of the sensor and well is critical for safe and accurate control operation!

The dual Temperature/LWCO sensor is designed to be used only with Beckett AquaSmart controls and Beckett immersion wells to provide temperature sensing for high limit, low limit, circulator operation and low water cutoff sensing. **The Temperature/ LWCO sensor must be used with a Beckett immersion well to provide the low water cutoff (LWCO) function. The LWCO function will not operate properly in a conventional immersion well or non-Beckett LWCO well.**

If using the Temperature/LWCO sensor in a non-Beckett well, turn off the LWCO function in the 7610 LWCO menu or install a Beckett immersion well if the LWCO function is required. The Temperature/ LWCO sensor is not tested or approved for strap-on or surface mounting to the outside of a pipe.

### CAUTION

For proper operation, there must be a secure electrical connection between the green sensor wire from the Temperature/LWCO sensor and the metal boiler vessel containing the boiler water. Failure to provide a secure electrical connection will result in the 7610 control locking out and displaying, "LOCKOUT - WATER LOW".

**Figure 11 – Temperature Sensor Lead/ Receptacle Connection**

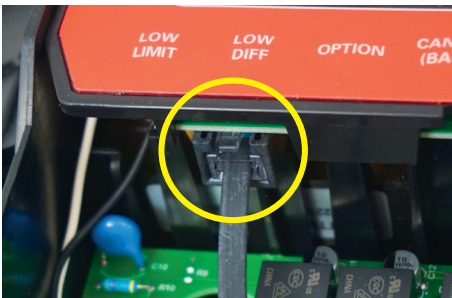

**Figure 12 – Retaining Clip**

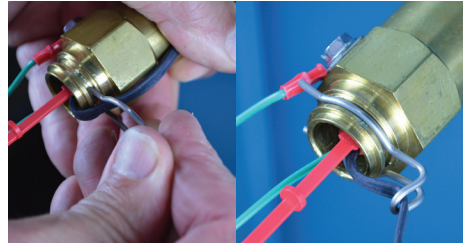

### WARNING

#### Explosion, Burn and Scald Hazards

*Excessive water temperatures could cause explosion, burns, scalding, pressure relief flooding and fitting leaks.*

- The Temperature Only or Temperature/LWCO Sensors and wells should only be installed by a trained professional.
- The sensor must be installed in the proper location for correct temperature sensing and proper low water cut-off (LWCO) operation in accordance with the Boiler Manufacturer's instructions.
- Carefully follow the outlined procedures for sensor installation to ensure accurate water temperature sensing and effective control operation.
- Make sure the plumbing for domestic hot water has anti-scald valve protection.
- Follow all applicable safety codes, rules and guidelines for installing an immersion well and sensor. Improper installation can result in the boiler overheating.
- Test appliance for correct limit operation following installation of an AquaSmart control or sensor.

### NOTICE

The inside of the well must be dry before installing sensor. Moisture in the well could lead to premature failure.

If the current installation includes a Beckett 2N1S one-piece sensor/well, we recommend replacing the 2N1S sensor/well with the 7600P/7630P Temperature/LWCO sensor and a separate Beckett immersion well of the same size and insertion.

1. A matching Beckett immersion well must be used for the low water cutoff function to operate properly. If a non-Beckett well has been installed, the existing well must be removed and replaced with a Beckett well matching the insertion and insulation dimensions of the original well. Make sure the immersion well is clean and dry inside, has no leaks, and has no dents that would prevent proper insertion of the new sensor. If unsure of the well condition or if deposit build up is suspected, replace the well. See *Installing the Well*.
2. With power to the control off, insert the sensor into the well. On the 7630P, grasp the pushrod, sensor cable and green wire as shown in **Figure 13**. Insert the sensor into the well with the pushrod on top (See **Figure 13**). Use the pushrod to make sure the sensor is fully seated in the well. You will feel a slight resistance when the sensor pin reaches the clip in the well (See **Figure 10**). Continue pushing until the sensor comes to a solid stop. The sensor pin must be fully inserted into the well clip for LWCO operation and proper temperature sensing.
3. For the 7630P, once the sensor is fully inserted, cut the pushrods shown in **Figure 14** to match the well insertion lengths listed in **Table 2** on page 10. For well mount applications, choose the disc furthest out on the push rod that will still allow the door to close completely. No trimming is needed for 4-3/4" wells. Do not cut or damage sensor lead wires.
4. Insert the telephone type sensor connector into the plug on the display as shown in **Figure 11**.
5. If the control is mounted remotely, additional sensor cable length may be needed to reach the sensor plug-in on the control. Use the extension cable (part no. 52120), found in the 7600RMU Remote Mount Kit, to extend the lead by 48".
6. For remote mount installations, install sensor retaining clip (Part No. 4582-001) as shown in **Figure 12**. Place cable between groove in the clip and attach clip into groove of immersion well. This anchors the sensor securely inside the immersion well. On remote mount applications, clipping the pushrod is still recommended.

### NOTICE

Following a sensor installation or sensor replacement, allow 20 seconds after power is applied for sensor self-check and communications check.

**Figure 13 – Inserting Sensor in Well**



**Figure 14 – Clipping the Pushrod to correct size**

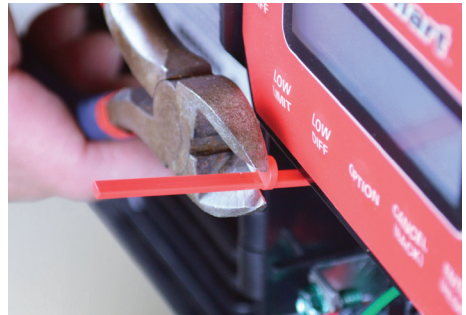



## Connecting the Green LWCO Circuit Completion Wire

- Proper connection of the green LWCO sensor wire is critical for correct operation of the LWCO circuit.
- DO NOT USE TEFLON TAPE FOR SEALING BECKETT BRASS WELLS ON LWCO APPLICATION. The Teflon tape will prevent proper operation of the LWCO circuit.
- In some applications, a pipe clamp (see **Figure 15**) has been used to secure the green wire to the incoming water feed pipe.

### Well Mount 7610 Applications with Beckett 7622TW Brass-Copper Well

1. Secure the fork connector on the green sensor wire to one of the two green screw terminals on the 7610 as shown in **Figure 16**. The 7610 provides a direct connection to the well mounting bracket which for the brass well will complete the LWCO connection to the boiler vessel.
2. Check connection to boiler vessel by taking an ohm reading between one of the green screws and metal on the boiler vessel (not the boiler jacket). A readings of 5K ohms or less should provide the connection needed for LWCO operation.

### Remote Mount 7610 Applications with Beckett 7622TW Brass-Copper Well

1. Secure the fork connector on the green sensor wire to the screw inserted into one of the tapped holes on the hex of the brass body of the well. Tighten the screw completely. See **Figure 17**.
2. Check connection to boiler vessel by taking an ohm reading between the screw and metal on the boiler vessel (not the boiler jacket). A readings of 5K ohms or less should provide the connection needed for LWCO operation.

**Figure 15 – Ground Clamp & Grounding Wire**

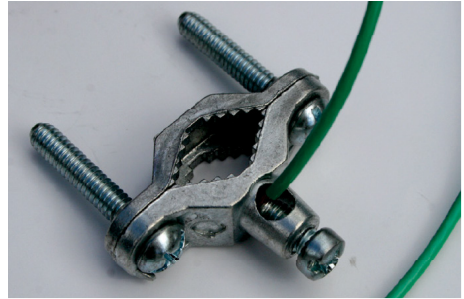

#### **NOTICE**

Following a sensor installation or sensor replacement, allow 20 seconds after power is applied for sensor self-check and communications check.

**Figure 16 – Well Mount Green Screw Connections**

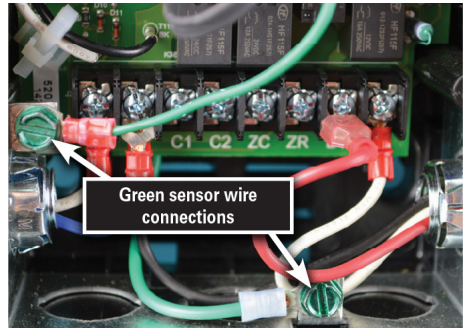

**Figure 17 – Remote Mount Green Wire Connection**

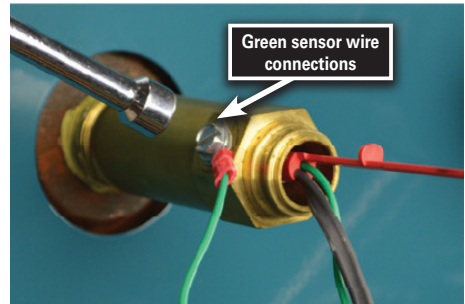

# AquaSmart Navigation Guide

## Current Operating Status:

- Standby
- Economizing
- Circulating
- Heating WTR
- Heating DHW
- Freeze Res

## LWCO Status

- On
- Off
- NA (Temp Only)

## Water Temperature or Setpoint

Push to Check or Set  
**High Limit Setpoint**

Push to Check or Set  
**High Limit Differential**

Push to Check or Set  
**Low Limit Setpoint**

Push to Check or Set  
**Low Limit Differential**

Push to access  
**Option Menu**

**OPTION**

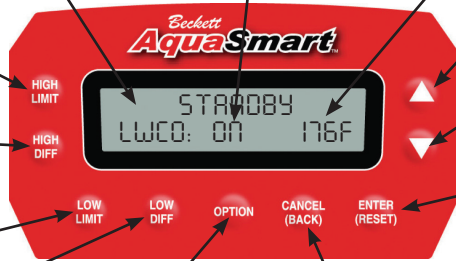

## Up Button

Tap to Move 1°F  
Hold to Move 5°F

## Down Button

Tap to Move 1°F  
Hold to Move 5°F

## Enter or (Reset)

Manual reset of LWCO  
or self check lockout

## Cancel or Back

- Operation - Hold down for temporary stop
- Option Menu - Hold down to return to status screen

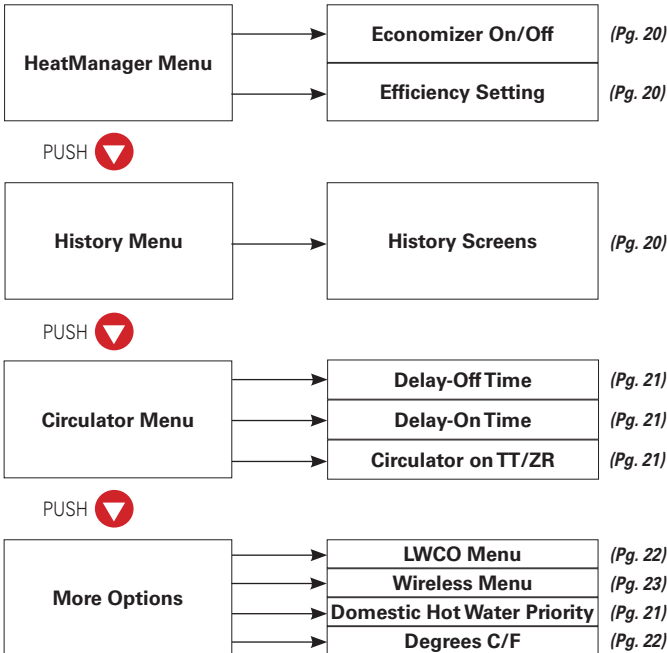

# Set Up and Programming

## **WARNING**

### **Electrical Shock Hazard.**

*Can cause severe injury, death, or equipment damage.*

Live line voltage wires and connections will be exposed while programming the AquaSmart. Touch only the AquaSmart keypad while programming the control.

## **CAUTION**

*Even with no call for heat from thermostats or zone controls, ignition and burners may start when power is applied to the 7610 if the control is programmed for low limit or indirect water heater operation.*

## 7610 Start Up

1. Verify all wiring connections from the appliance to the 7610 control are correct. Make sure thermostats or zone controls are not set to call for heat.
2. Be sure there is water in the boiler and all plumbing connections are complete and tight before applying power to the appliance or 7610 control.
3. Restore power to the appliance and the 7610 control. The LCD display should light and the words "Beckett AquaSmart" should briefly appear on the screen.



4. Screen will quickly move to the status screen. It may take up to 20 seconds for the sensor to go through self check and clear any sensor errors.



5. If the HeatManager program is active, the display will alternate every 5 seconds between the Status Screen and the Economizing Screen. The temperature shown on the Economizing screen is the economized High Limit setpoint.

LWCO: NA = Temperature only sensor

For additional status screens see 7610 Status Messages.

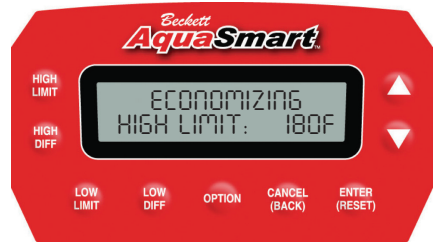

# Programming Basic Functions

**WARNING** Fire, Explosion, and Burn Hazards.

Can cause severe injury, death, or equipment damage.

Do not set the operating limits of the control outside of those listed by the appliance manufacturer.

**WARNING** Burn and Scald Hazard

Excessive water temperatures could cause explosion, burns, scalding, pressure relief flooding and fitting leaks.

Make sure the plumbing for domestic hot water has anti-scald valve protection and that domestic hot water temperature does not exceed 120°F at the tap.

**WARNING** Electrical Shock Hazard.

Can cause severe injury, death, or equipment damage.

Live line voltage wires and connections will be exposed while programming the AquaSmart. Take care to touch only the AquaSmart keypad while programming the control.

**NOTICE** When programming temperature settings, the 7610 may prevent some combinations of High and Low Limits settings or High and Low Differential settings. If you are not able to change a setpoint or differential within the range normally allowed by the control, there is a conflict with the setpoints or differentials.

Figure 18 – AquaSmart Keypad & Display

**Programming Tip:** During setup and programming, the bottom line of the display will provide guidance on the next step in programming.

The display will change with each key press. If the display does not change, the key press did not register.

## A. Set High Limit Temperature

- Starting from the Status Screen -



Keypad Instructions	Screen
<b>STEP 1</b>	
Press: 	HIGH LIMIT: 180F CHANGE AND ENTER
<b>STEP 2</b>	
Press arrows to set temperature: 	
<b>STEP 3</b>	
Press when temperature is set: 	HIGH LIMIT: 180F ENTER OR CANCEL
<b>STEP 4</b>	
Press again to confirm and lock setting:   - or - Press to cancel changes: 	

**IMPORTANT:** Refer to appliance manufacturer's recommendation for high limit temperature settings.

## B. Set Low Limit Temperature

- Starting from the Status Screen -







Keypad Instructions	Screen
<b>STEP 1</b>	
Press: 	LOW LIMIT: 150F ENTER OR CANCEL
<b>STEP 2</b>	
Press arrows to set temperature: 	
<b>STEP 3</b>	
For Cold Start Boilers, press down arrow until "OFF": 	LOW LIMIT: OFF ENTER OR CANCEL

Keypad Instructions	Screen
<b>STEP 4</b>	
Press when temperature is set: 	LOW LIMIT: 140F CHANGE AND ENTER
<b>STEP 5</b>	
Press again to confirm and lock setting:   - or - Press to cancel changes: 	

**IMPORTANT:** Refer to appliance manufacturer's recommendation for high limit temperature settings.

### C. Set High Limit Differential

- Starting from the Status Screen -

Keypad Instructions	Screen
<b>STEP 1</b>	
Press: 	HIGH DIFF: 10F CHANGE AND ENTER
<b>STEP 2</b>	
Press arrows to set differential:  	
<b>STEP 3</b>	
Press when differential is set: 	HIGH DIFF: 20F CHANGE AND ENTER
<b>STEP 4</b>	
Press again to confirm and lock setting:   - or - Press to cancel changes: 	

**IMPORTANT:** Refer to appliance manufacturer's recommendation for high limit temperature settings.

See "How a Boiler Control Works" on page 19 for help in understanding High and Low Limit Temperature Differentials.

**NOTICE** To prevent rapid cycling of the equipment, the 7610 requires a separation between the HIGH and LOW LIMIT setpoints. The separation is equal to the larger of the two differentials plus 5°F.

**Example:**

HIGH LIMIT = 180°F  
HIGH DIFF = 20°F  
LOW DIFF = 10°F

- Larger DIFF = 20°F
- Minimum separation = 25°F (larger differential + 5°F).
- Highest LOW LIMIT setting allowed = 155°F.
- 180°F - 25°F = 155°F

**Beckett recommends at least a 10° F separation between the LOW LIMIT setpoint and the bottom temperature of the HIGH LIMIT DIFFERENTIAL.**

Example:

$$\text{HIGH LIMIT} - \text{HIGH DIFF} - 10^\circ\text{F} = \text{LOW LIMIT}$$







$$180^\circ\text{F} - 20^\circ\text{F} - 10^\circ\text{F} = 150^\circ\text{F}$$

Highest Recommended LOW LIMIT setting = 150°F

Less separation between the LOW LIMIT setting and the bottom temperature of the HIGH LIMIT DIFFERENTIAL could lead to unwanted cycling of the circulator.

### D. Set Low Limit Differential

- Starting from the Status Screen -

Keypad Instructions	Screen
<b>STEP 1</b>	
Press: 	LOW DIFF: 10F CHANGE AND ENTER
<b>STEP 2</b>	
Press arrows to set differential:  	
<b>STEP 3</b>	
Press when differential is set: 	LOW DIFF: 15F CHANGE AND ENTER
<b>STEP 4</b>	
Press again to confirm and lock setting:   - or - Press to cancel changes: 	



## How a Boiler Control Works

**Figure 19 – Cold Start Operation (Low Limit ► OFF)**

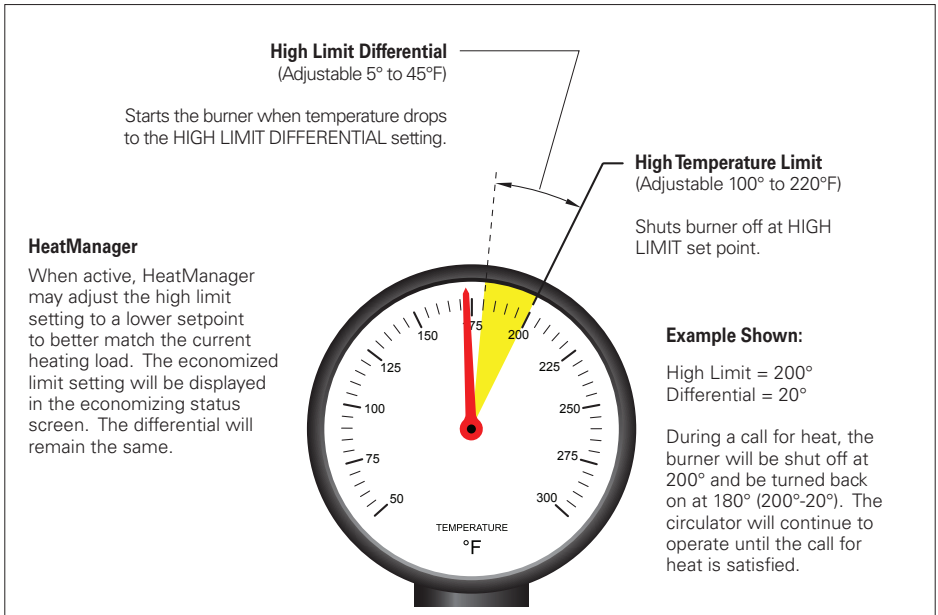

**Figure 20 – Warm Start Operation (Low Limit ► ON) (To maintain domestic hot water temperature)**

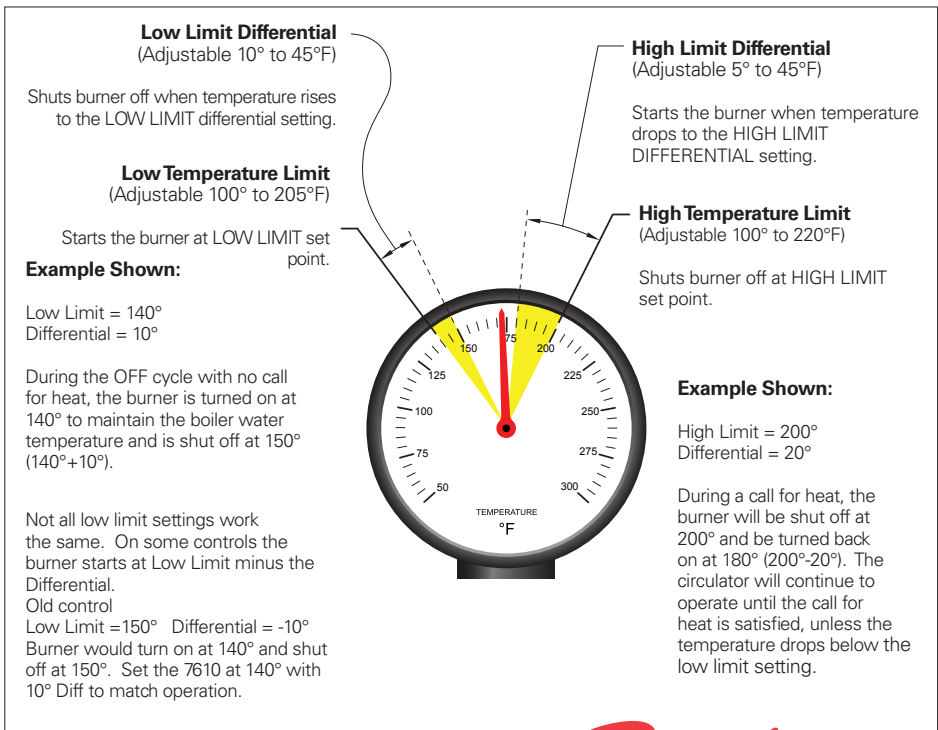

## Additional Programming Options

### Heat Manager

The Beckett 7610 HeatManager logic meets Department of Energy (DOE) 2012 requirements for an automatic means of adjusting boiler water temperature. The HeatManager algorithm saves fuel by adjusting the operating temperature of the boiler water to the minimum temperature needed to meet the heating demand. In milder weather, when the full heating capacity of the boiler is not needed, the high limit setting is adjusted down to save fuel. When the HeatManager is active, the "Economizing" display will alternate with the standard status display.

ECONOMIZING  
HIGH LIMIT: 170F



The temperature shown is the economized high limit setting. If the economizing high limit shown matches the limit set point, it simply means that full heating capacity is required to maintain room temperature.





The three efficiency settings for the HeatManager "HI", "LOW" and "MED" allow qualified service technicians to customize the operation of the control to best balance energy savings and comfort. The "HI" setting will provide the greatest energy savings. The "LOW" and "MED" will provide less energy savings but may provide better comfort while still saving energy.

If the HeatManager has lowered the high limit setting and a call for heat is received, the control will gradually increase the limit setting to meet the demand for heat. If the call for heat lasts more than 20 minutes, the control will reset the high limit setting to the original limit set point to provide maximum heating capacity.

### A. Changing the Heat Manager Settings





- Starting from the Status Screen -

Keypad Instructions	Screen
<b>STEP 1</b>	
Press: 	HEAT MANAGER MENU ENTER TO VIEW
<b>STEP 2</b>	
Press: 	ECONOMIZER: ON ENTER TO CHANGE
<b>STEP 3</b>	
Press to toggle between ON / OFF: 	ECONOMIZER: OFF ENTER TO CHANGE
or move to step 4	

Keypad Instructions	Screen
<b>STEP 4</b>	
Press to move to Efficiency Screen: 	EFFICIENCY: HI ENTER TO CHANGE
<b>STEP 5</b>	
Press to change to Efficiency Screen: 	EFFICIENCY: LOW ENTER TO CHANGE
<b>STEP 6</b>	
Press to change to Efficiency Setting:  or move to Step 7	EFFICIENCY: MED ENTER TO CHANGE
<b>STEP 7</b>	
Press and hold  This will lock settings, exit and return to Status Screen	

### B. Viewing the Cycle History

The History Menu provides information on the last 9 control cycles. This information can be helpful in identifying issues with control operation. Using the History Menu is covered in detail under "Additional Diagnostic Information - History" on page 31.

Keypad Instructions	Screen
<b>STEP 1</b>	
Press:  	HISTORY MENU ENTER TO VIEW
<b>STEP 2</b>	
Press: 	1 ON) 2:15 OFF) 30:05 140F
<b>STEP 3</b>	
Press to scroll through cycle history: 	

Keypad Instructions	Screen
<b>STEP 4</b>	
Press and hold to exit and return to Status Screen.	
	

## C. Changing the Circulator Settings

Adjusting the circulator settings allows the technician to configure the circulator operation to best fit the needs of the application.











The Circulator-Off Delay holds the C1 circulator output on after a call for heat ends. Running the circulator longer may help system efficiency by transferring more heat from the boiler into the home. Many systems lose heat in the boiler to unheated spaces during long off cycles.













The Circulator-On Delay holds the C1 circulator output off at the start of a call for heat. This helps the boiler heat up more quickly, prevents circulating cold water and allows cold start boilers to move through the condensing range more quickly.

**Both circulator delays are selectable from 0:00 to 4:15 (4 minutes and 15 seconds).**

The Circulator On setting selects whether the circulator is energized by calls for heat from TT (Thermostat), ZR (Zone Relay) or both.

### - Starting from the Status Screen -

Keypad Instructions	Screen
<b>STEP 1</b>	
Press:   	CIRCULATOR MENU ENTER TO VIEW
<b>STEP 2</b>	
To Set Delay Off, Press: 	DELAY OFF: 0:00 ENTER TO CHANGE
<b>STEP 3</b>	
Press to change  -OR- Press to Skip 	
If changing, use arrow keys to set delay time  	DELAY OFF: 0:00 ENTER TO CHANGE
When time is set, press: 	DELAY OFF: 1:00 ENTER OR CANCEL
Press to confirm and lock setting 	DELAY OFF: 1:00 ENTER TO CHANGE

Keypad Instructions	Screen
Press to move to set Delay On 	
<b>STEP 4</b>	
To set Delay On	DELAY ON 0:00 ENTER TO CHANGE
Press to change  -OR- Press to Skip 	
If changing, use arrow keys to set delay time  	DELAY ON: 0:00 CHANGE AND ENTER
When time is set	DELAY ON: 1:00 CHANGE AND ENTER
Press: 	DELAY ON: 1:00 ENTER OR CANCEL
Press to confirm and lock setting 	DELAY ON: 1:00 ENTER OR CHANGE
Press to move to set Circulator On 	
<b>STEP 5</b>	
To set Circulator On setting	CIRC: ON TT ENTER TO CHANGE
Press to change  -OR- Press to Skip 	
One press will set to ZR	CIRC: ON ZR ENTER TO CHANGE
Press again for BOTH 	CIRC: ON BOTH ENTER TO CHANGE
<b>STEP 6</b>	
When all circulator settings are correct, press and hold: 	
This will lock settings, exit and return to Status Screen	

## D. Changing Domestic Hot Water











## Priority (DHWP) Setting

The Domestic Hot Water Priority function is typically used with indirect or storage type domestic hot water systems. DHWP provides a temporarily override of other control functions to make sure domestic hot water will be produced when needed. As part of the override function, the circulator for space heating is normally turned off. This could be either the C1 or ZC outputs, depending on the DHWP setting and circulator source settings. This gives priority to meeting demand for domestic hot water. After 20 minutes of a continuous domestic hot water priority, the circulator C1 or ZC will again be energized.

The DHWP setting selected will depend on how the hot water system is set up. Use the TT setting if the signal calling for domestic hot water is 24 volts. Use the ZR setting if the signal for domestic hot water is 120 volts.

Additional wiring diagram examples are available in the Beckett publication "Guide to Energy Savings" part # 61856. This publication is available on line at [www.beckettcorp.com](http://www.beckettcorp.com) or through your local Beckett Distributor.











### - Starting from the Status Screen -

Keypad Instructions	Screen
<b>STEP 1</b>	
Press:    	MORE OPTIONS ENTER TO VIEW
<b>STEP 2</b>	
Press:   	DHWP: OFF ENTER TO CHANGE
<b>STEP 3</b>	
Press: 	DHWP: ON ZR ENTER TO CHANGE
<b>STEP 4</b>	
Press: 	DHWP: ON TT ENTER TO CHANGE
<b>STEP 5</b>	
When the DHWP setting is correct, press and hold 	This will lock settings, exit and return to Status Screen

## E. Selecting Fahrenheit or Celsius

## Temperature Display

### - Starting from the Status Screen -

Keypad Instructions	Screen
<b>STEP 1</b>	
Press:    	MORE OPTIONS ENTER TO VIEW
<b>STEP 2</b>	
Press:    	DEG (F/C): F ENTER TO CHANGE
<b>STEP 3</b>	
Press to toggle between °F and °C: 	
<b>STEP 4</b>	
Press and hold 	
This will lock settings, exit and return to Status Screen	

## F. Changing Low Water Cutoff (LWCO) Settings

The function of the Low Water Cutoff in the 7610 is to prevent the burner from firing if there is not enough water in the boiler to fire the boiler safely. The LWCO function can only be used when a Beckett dual Temperature/LWCO sensor and a Beckett immersion well are installed with the 7610.

**DELAY OFF** = 0-30 seconds. Delays shutting down the control and burner in a low water condition.

**DELAY ON** = 0-255 seconds. Delays turning on the burner when the water returns to a level high enough for safe operation.

**If either delay timing is changed you must allow for the additional timing when testing LWCO function.**

- RESET = AUTO (automatic)

The control will automatically resume operation when the water level returns to safe levels.

- RESET = MAN (manual)

The **ENTER(RESET)** button must be held for 5 seconds before the control will resume operation.













- RESET = OFF



OFF setting turns the LWCO protection off.

OFF should only be used when a Beckett dual Temperature/LWCO sensor is used in a non-Beckett immersion well.

“LWCO: OFF” will be displayed on the status screen. Do not use the off setting in applications where Low Water Cutoff is required unless a separate LWCO control is installed. Either replace the existing well with a Beckett immersion well or install a separate LWCO Control.

**- Starting from the Status Screen -**

Keypad Instructions	Screen
<b>STEP 1</b>	
Press:    	MORE OPTIONS ENTER TO VIEW
<b>STEP 2</b>	
Press: 	LWCO MENU ENTER TO VIEW
<b>STEP 3</b>	
Press: 	DELAY OFF: 0:00 ENTER TO CHANGE
Press to change 	-OR-
Press to Skip 	
If changing	DELAY OFF: 0:00 CHANGE AND ENTER
Use arrow keys to set delay time  	DELAY OFF: 0:10 CHANGE AND ENTER
When time is set, press: 	DELAY OFF: 0:10 ENTER OR CANCEL
Press to confirm and lock setting 	DELAY OFF: 0:10 ENTER TO CHANGE
Press to move to set LWCO Delay On 	

Keypad Instructions	Screen
<b>STEP 4</b>	
Repeat Steps 1 - 3 to set LWCO On.	
Press to move to set LWCO Reset 	
<b>STEP 5</b>	
Press to select LWCO Reset Mode: 	RESET: AUTO ENTER TO CHANGE  RESET: OFF ENTER TO CHANGE  RESET: MAN ENTER TO CHANGE
<ul style="list-style-type: none"> <li>• OFF setting turns the LWCO protection off.</li> <li>• OFF should only be used when a Beckett dual Temperature/LWCO sensor is used in a non-Beckett immersion well.</li> <li>• “LWCO: OFF” will be displayed on the status screen. Do not use the off setting in applications where Low Water Cutoff is required unless a separate LWCO control is installed. Either replace the existing well with a Beckett immersion well or install a separate LWCO Control.</li> </ul>	
<b>STEP 6</b>	
When the LWCO Reset setting is correct, press and hold 	
This will lock settings, exit and return to Status Screen	

When all programming is complete, move to the section **Start Up and Checkout**.

**G. Wireless Outdoor Reset Menu**

The Wireless Outdoor Reset Menu is only accessible when the 7600WTMU wireless outdoor reset module with transmitter and wireless sensor is installed.

NOT INSTALLED

See Wireless Temperature Module Installation Manual (61776) for complete instructions.



# Start Up and Checkout

## New Boiler Installation - Checklist

For New Boilers with the 7610 control already installed.

- Follow the instructions for start up included with the boiler.
- Make sure all wiring connections match the appliance wiring diagram.
- If accessories, including zone valves, zone relays or zone panels are installed, make sure all wiring matches the manufacturers instructions. Additional wiring diagram examples are available in the Beckett publication "Guide to Energy Savings" part # 61856. This publication is available on line at [www.Beckettcorp.com](http://www.Beckettcorp.com) or through your local Beckett Distributor.
- Make sure the sensor is correctly installed and fully seated in the immersion well. See *Installing the Temperature Only Sensor or Installing the Temperature/LWCO Sensor*. Clip pushrod if needed to close door.
- Check all thermostat connections for proper polarity and set thermostats not to call for heat.
- Be sure there is water in the boiler and all plumbing connections are complete before applying power to the appliance.
- Once power is applied, the 7610 display should light up and the words Beckett AquaSmart will appear briefly.
- Current Operating Status, Low Water Cutoff status and Water Temperature will be displayed.
  - LWCO: NA = Temperature Only Sensor
  - LWCO: OFF or ON = LWCO program status
- Check all control settings to make sure they match the settings recommended by the boiler manufacturer. See *Programming Basic Functions and Additional Programming Options* for instructions.
- The Circulator settings and the Domestic Hot Water Priority settings may require changes if using an indirect water heater or pumps for zoning. See *Additional Programming Options* for instructions.
- Follow Checkout Procedure.

## Replacement Control Installation

- Follow all steps in the Installation, Wiring and Programming sections of the manual.
- Make sure all settings are correct.
- Make sure the sensor is correctly installed and fully seated in the immersion well. See *Installing the Temperature Only Sensor or Installing the Temperature/LWCO Sensor*.
- Follow Checkout Procedure.

## Control Checkout Procedure



**CAUTION** *Even with no call for heat from thermostats or zone controls, ignition and burner(s) may start when power is applied to the 7610 if the control is programmed for low limit or indirect water heater operation.*

The instructions below provide procedures for several common control configurations. Other configurations are possible. Make sure high limit, low limit, circulator and domestic hot water functions are tested and operating properly.

### Boiler with Low Limit Setting

Circulator = ON TT

DHWP = OFF

Start with No Call for Heat

1. If water temperature is below Low Limit setting:
  - Low Limit starts Burner
  - Display = HEATING WTR
  - B1 = On C1, ZC = Off
2. When water temperature reaches Low Limit + DIFF:
  - Burner turns off
  - Display = STANDBY
  - ZC = On B1, C1 = Off
3. Set room thermostat or zone to call for heat:
  - Burner and Circulator turn on
  - (Circulator may have a delay on timing)
  - Display = HEATING WTR
  - B1, C1, ZC = on
4. When water temperature reaches High Limit:
  - Burner turns off
  - Display = CIRCULATING
  - C1, ZC = On B1 = off
5. Turn thermostat down to end call for heat:
  - Circulator turns off
  - (Circulator may have a delay off timing)
  - Display = STANDBY
  - ZC = On B1, C1, = Off

### Cold Start Boiler

Low Limit = OFF

Circulator = ON TT

DHWP = OFF

Start with No Call for Heat

1. Set room thermostat or zone to call for heat:  
Burner and Circulator turn on  
(Circulator may have a delay on timing)  
Display = HEATING WTR  
B1, C1, ZC = on
2. When water temperature reaches High Limit:  
Burner turns off  
Display = CIRCULATING  
C1, ZC = On B1 = off
3. Turn thermostat down to end call for heat:  
Circulator turns off  
(Circulator may have a delay off timing)  
Display = STANDBY  
ZC = On B1, C1 = Off

### Cold Start Boiler with Indirect Water Heater

#### Domestic Hot Water Priority = ZR

Low Limit = OFF

Circulator = ON TT

DHWP = ZR

Start with No Call for Heat

1. If water temperature in Indirect Water Heater is below the domestic hot water setting:  
ZR starts burner  
Circulator (C1) remains off  
Display = HEATING DHW  
ZR, B1, ZC = On C1 = Off
2. When the domestic hot water control temperature reaches setting plus differential:  
Burner turns off  
Circulator (C1) remains off  
Display = STANDBY  
ZC = On ZR, B1, C1, = Off
3. Set room thermostat or zone to call for heat:  
Burner and Circulator (C1) turn on  
(Circulator may have delay on timing)  
Display = HEATING WTR  
B1, C1, ZC = On ZR = Off

4. When water temperature reaches High Limit:  
Burner turns off  
Circulator (C1) remains on  
Display = CIRCULATING  
C1, ZC = On B1, ZR = Off
5. Turn thermostat down to end call for heat:  
Circulator (C1) turns off  
(Circulator may have delay off timing)  
Display = STANDBY  
ZC = On B1, C1, ZR = Off

### Cold Start Boiler with Indirect Water Heater Domestic Hot Water Priority = TT

Low Limit = OFF

Circulator = ON TT

DHWP = TT

(Circulator delays will only effect DHW zone)

Start with No Call for Heat

1. If water temperature in Indirect Water Heater is below the domestic hot water setting:  
TT starts burner and circulator (C1)  
(Circulator may have delay on timing)  
Display = HEATING DHW  
B1, C1 = On ZC, ZR = Off
2. When domestic hot water temperature reaches setting plus differential:  
Burner turns off  
Circulator (C1) turns off  
(Circulator may have delay off timing)  
Display = STANDBY  
ZC = On ZR, B1, C1, = Off
3. Set room thermostat or zone to call for heat:  
ZR starts burner  
Circulator (C1) remains off  
Display = HEATING WTR  
B1, ZR, ZC = On C1 = Off
4. When water temperature reaches High Limit:  
Burner turns off  
Display = STANDBY  
ZR, ZC = On B1, C1 = Off
5. Turn thermostat down to end call for heat:  
ZR turns off  
Display = STANDBY  
ZC = On B1, C1, ZR = Off

#### CAUTION

Do not leave the installation site without confirming correct operation of the high limit, low limit (if used), thermostats and domestic hot water (if included). The above procedures help to verify that the high and low limits are working properly and that the thermostat is wired correctly to the control. If a LWCO sensor is used, complete test on next page.

## Low Water Cutoff Test Procedure

Many local codes require testing the low water cutoff function as part of the start up procedure.



### WARNING

#### Electrical Shock Hazard.

*Can cause severe injury, death, or equipment damage.*

Live line voltage wires and connections may be exposed while testing the low water cutoff. Do not touch any wiring or terminals with fingers or the sensor.

1. Set LWCO DELAY OFF and DELAY ON times to 0:00 (default) for testing. Reset = Auto.

```
STANDBY
LWCO: 0N 180F
```

Note: LWCO:NA = Temperature Only sensor. Sensor must be changed to 7630P or 7600P sensor to provide LWCO function.

2. Pull the sensor out 1-2 inches. You will feel the clip release the sensor pin. Make sure the sensor pin is not in contact with the side of the well.
3. Within 20 seconds, the control should enter low water lockout.

```
LOCKOUT
WATER LOW
```

4. Reinsert the sensor and make sure the sensor is fully seated in the well. Within 20 seconds, the control should exit low water lockout.

```
STANDBY
LWCO: 0N 180F
```

5. If changes were made to the LWCO DELAY ON, or DELAY OFF timings for testing, reprogram the delay timings. If Manual LWCO reset is required, reprogram Reset = MAN.

## 7610 Operation

**Table 3 – Typical operation with default settings (Circulator set “ON TT”)**

System Action	7610 Response
Temperature falls below low limit	<ul style="list-style-type: none"> <li>• Burner is turned on until the water temperature reaches the low limit plus the low differential.</li> <li>• ZC is turned off until the water temperature reaches the low limit setting plus the low limit differential LL+ LLD</li> </ul>
Thermostat call for heat	<ul style="list-style-type: none"> <li>• Burner is turned on as long as the water temperature is below the high limit.</li> <li>• Circulator is turned on after circulator-on delay if the low limit is satisfied.</li> </ul>
Thermostat is satisfied	<ul style="list-style-type: none"> <li>• Burner is turned off.</li> <li>• Circulator is turned off after circulator-off delay</li> </ul>
ZR call for heat	<ul style="list-style-type: none"> <li>• Burner is turned on as long as the water temperature is below the high limit.</li> </ul>
ZR is satisfied	<ul style="list-style-type: none"> <li>• Burner is turned off.</li> </ul>
Temperature reaches high limit	<ul style="list-style-type: none"> <li>• Burner is turned off until the water temperature falls below the high limit minus the high differential.</li> </ul>
Circulator is inactive for 3 days	<ul style="list-style-type: none"> <li>• Circulator is turned on for 2 seconds to help prevent seizure.</li> </ul>
7610 locks out	<ul style="list-style-type: none"> <li>• Burner, Circulator, and ZC are turned off until the control is reset. The lockout condition may reset automatically or require a manual reset. See Lockout Messages section.</li> </ul>
B1 has been energized for 3 hours or 7610 has been locked out for 3 hours	<ul style="list-style-type: none"> <li>• Circulator and ZC are turned on to help prevent system freeze-up by circulating the boiler water to all zones. FREEZE RES</li> </ul>
Priority call for heat	<ul style="list-style-type: none"> <li>• If DHWP is set on T-T and there is a T-T call for heat, ZC is held off for up to 20 minutes to give the DHW zone priority.</li> <li>• If DHWP is set on ZR and there is a ZR call for heat, C1 is held off for up to 20 minutes to give the DHW zone priority.</li> </ul>

## 7610 Status Messages

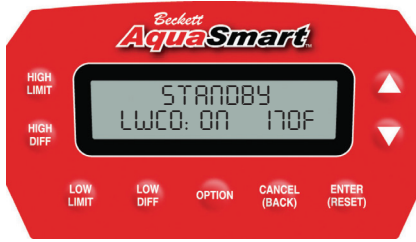

Message Displayed	
STANDBY LWCO:ON 170F	<ul style="list-style-type: none"> <li>Standby is displayed when the burner and the circulator (C1) are both off.</li> <li>The temperature displayed is the current water temperature</li> </ul>
ECONOMIZING LWCO:ON 166F	<ul style="list-style-type: none"> <li>Economizing is displayed when the Heat Manager is active and controlling the high limit setting.</li> <li>The temperature displayed is the adjusted high limit temperature.</li> <li>The Economizing message will alternate every 5 seconds with other status messages.</li> </ul>
CIRCULATING LWCO:ON 182F	<ul style="list-style-type: none"> <li>Circulating is displayed when the circulator (C1) is energized and the burner is off.</li> </ul>
HEATING WTR LWCO:ON 158F	<ul style="list-style-type: none"> <li>Heating water is displayed when the call for heat comes from a non-priority zone (room heat) or when the low limit calls for heat.</li> <li>The burner will be on.</li> </ul>
HEATING DHW LWCO:ON 158F	<ul style="list-style-type: none"> <li>Heating domestic hot water will be displayed when the call for heat comes from the DHW zone or the zone designated for heating priority.</li> <li>The burner will be on.</li> <li>The temperature displayed is the temperature of the water in the boiler, not the temperature in the water heater.</li> </ul>
FREEZE RES LWCO:ON 130F	<ul style="list-style-type: none"> <li>Freeze Resistance is displayed when a call for heat has been on continuously for 3 hours or the 7610 has been in lockout for 3 hours.</li> <li>ZC will be energized and C1 will be energized if there is a call for heat.</li> <li>If the 7610 is in lockout, this message will alternate with the lockout message. FREEZE RES by itself is not a lockout condition.</li> <li>See Freeze Resistance for additional information.</li> </ul>

Message Displayed	
STANDBY LWCO:ON 170F	<ul style="list-style-type: none"> <li>LWCO sensor is installed and the LWCO protection is active</li> </ul>
STANDBY LWCO:OFF 170F	<ul style="list-style-type: none"> <li>LWCO protection has been turned off in the control menu.</li> </ul>
STANDBY LWCO:NA 170F	<ul style="list-style-type: none"> <li>A temperature only sensor is installed. LWCO protection is not available</li> </ul>

## Freeze Resistance

Freeze Resistance or "FREEZE RES" provides an additional level of protection against freezing pipes caused by control or burner failures. The 7610 will try to circulate water through the heating pipes if there has been a continuous call for heat for 3 hours. This may help prevent freezing in the heating pipes in some failure conditions.

FREEZE RES IS NOT AN ERROR CODE AND DOES NOT LOCKOUT THE BURNER OR OVERRIDE THE CALL FOR HEAT. Some heating systems may routinely have calls for heat lasting more than 3 hours in severe weather. Freeze Resistance will not prevent the normal operation of these systems. The Freeze Res message will disappear when the call for heat is satisfied.

The Freeze Resistance mode is activated by:

1. A continuous call for heat for 3 hours.
2. A lockout of the 7610 control for 3 hours.
3. Low Limit function active for 3 hours.

In the Freeze Resistance mode:

1. If the circulator is already on, it will continue to run.
2. ZC is energized to allow zones to call for heat.
3. If a call for heat is active, C1 (circulator) will be energized.

7610 will not energize the circulator (C1) unless one of the zones fed by the circulator is calling for heat. This prevents damage to the pump from trying to circulate water when all zones are closed.

Freeze Resistance mode will end if:

1. The call for heat ends or the low limit is satisfied.
2. The high limit opens.
3. Power is interrupted.
4. The 7610 lockout condition is cleared.

To manually clear the Freeze Resistance mode, remove power from the control for 10 seconds. Removing and restoring power will reset the Freeze Resistance timer but will not reset a lockout condition.

More detailed information on Freeze Resistance operation is available in Beckett Technical Information Bulletin 60280. This publication is available at [www.beckettcorp.com](http://www.beckettcorp.com).

### **CAUTION** Frozen Plumbing and Water Damage Hazard

*If the residence is unattended in severely cold weather, boiler control safety lockout, heating system component failures, power outages or other electrical system failures could result in frozen plumbing and water damage in a matter of hours.*

For protection, take preventative actions such as having a security system installed that operates during power outages, senses low temperature and initiates an effective action. Consult your qualified service technician or a home security agency.

## Diagnostics and Troubleshooting



### Lockout Messages

1. Check the display screen for lockout message.
2. If lockout message is alternating with "Freeze Res" message, control has been in lockout for more than 3 hours. See Freeze Resistance.
3. Record the Data in the History Menu before cycling the control. Use the chart on page 32 of this manual to record the data. Cycling the control will replace the older cycles in the History memory.
4. Find the matching lockout message in the boxes below and follow the troubleshooting actions.

#### Message:

LOCKOUT  
SENSOR ERR

The sensor has detected an internal error or is not communicating properly with the 7610. This message applies to both temp only and dual temperature/LWCO sensors.

#### Actions:

1. Check boiler water temperature - over 250° F will display as Sensor Err.
2. Use the pushrod to make sure the sensor is fully seated in the well.
3. Check sensor connection to display module including sensor cable and extension, if used.
4. Unplug the sensor from the display - check connector for damage.
5. Check green sensor wire and connections.
6. Plug sensor back into display.
7. Wait 20 seconds.
8. If error clears, resume operation.
9. If error remains, replace sensor.
10. If replacement sensor still shows sensor error, replace control (wait 20 seconds for sensor communication and self-check).

**Message:**

LOCKOUT  
SELF CHECK

An internal safety check of the control has failed. For example; a failure of the check for welded contacts on the burner relay would cause a Lockout Self Check.

**Actions:**

1. Push and hold the ENTER (RESET) key for 5 seconds. This will reset the control from this lockout condition
2. Wait while the control goes through a diagnostic check.
3. If the error returns - replace the control.

**Message:**

LOCKOUT  
WATER LOW

The sensor and control are failing to detect water in the boiler. This message will only be seen with a dual function temperature and low water cutoff sensor like the 7600P/7630P.

**Actions**

1. Must be used with Beckett well for LWCO to work properly, non-Beckett well with result in Lockout water low.
2. Make sure the sensor is fully seated in the well and that the pin on the sensor engages the clip in the well. (See Installing the Temperature/LWCO Sensor)
3. Wait 20 seconds plus any delay programmed into the LWCO menu, if lockout clears, resume operation.
4. If lockout remains, turn off power to the control. Disconnect the green sensor wire and remove the sensor from the well. Leave the sensor cable plugged into the 7610 display.
5. Restore power to the control and place the end of the green sensor wire on the metal tip of the 7630P sensor. (Older 7600P sensors require the use of a 1K ohm resistor for this test. Place the resistor between the end of the green wire and the sensor tip.)
6. Wait 20 seconds plus any delay programmed into the LWCO menu, if the lockout clears the sensor is good. If the lockout does not clear, replace the sensor.

If the sensor is good: Other Possible Causes

- Poor connections in the LWCO circuit wiring
- Deposit build up on the well or boiler vessel
- Conductivity issues with the water in the boiler

## Temporary Stop

To stop all control function temporarily - hold down the CANCEL (Back) button. Normal operation will resume when the button is released. The stop function is not available in the OPTION Menu.

**During normal operation:**

Hold down  to stop all control functions

LOCKOUT  
CANCEL

Control will resume normal operation when the button is released.









## Troubleshooting

Issue	Suggested Actions
No Display	<ul style="list-style-type: none"> <li>• Push “▲” or “▼” to see if display backlight will come on.</li> <li>• Check 120 volt power to the control - if no power, restore 120 volts to control.</li> <li>• Remove wires attached to the T-T terminals and check for 24 volts at T-T.</li> <li>• If 120 volts to control but no 24 volts at T-T, transformer is bad, replace control (check for shorts or incorrect wiring before replacing control).</li> <li>• If voltages are correct, and still no display, replace control.</li> </ul>
Lockout Message	<ul style="list-style-type: none"> <li>• Follow the instructions under Lockout Messages for the message displayed.</li> </ul>
Freeze Res (no alternating Lockout message)	<ul style="list-style-type: none"> <li>• Call for heat has been continuous for 3 hours - may be normal operation in severe weather ( see Freeze Resistance section).</li> <li>• Check for burner operation—if burner is operating, check temperature in boiler.</li> <li>• If Burner is not operating, check for ignition control or oil primary lockout.</li> <li>• If burner is operating and water is hot, check for circulation issues.</li> </ul>
Circulator does not start on call for heat	<ul style="list-style-type: none"> <li>• Check for Circulator on delay in Option Menu.</li> <li>• Check Circulator On setting = TT, ZR, or Both.</li> </ul>
Circulator does not turn off at the end of a call for heat	<ul style="list-style-type: none"> <li>• Check for Circulator off delay in Option Menu.</li> </ul>
Burner does not come on	<ul style="list-style-type: none"> <li>• Check for power at B1 and B2.</li> <li>• Check for ignition control or oil primary lockout.</li> <li>• Check wiring for call for heat from TT or ZR.</li> <li>• Follow normal burner trouble shooting procedures.</li> </ul>
Burner turns on - no call for heat	<ul style="list-style-type: none"> <li>• Check Low Limit setting - Low Limit may be active.</li> </ul>
LWCO:NA	<ul style="list-style-type: none"> <li>• Temperature only sensor installed - no low water cutoff function.</li> </ul>

## Additional Diagnostic Information - History

Data for the last 9 cycles is kept under the History Menu. This information may be helpful in troubleshooting.

Keypad Instructions	Screen
<b>STEP 1</b>	
Press:  	HISTORY MENU ENTER TO VIEW
<b>STEP 2</b>	
Press for first part of Cycle 1: 	1 ON) 20:18 OFF) 32:15 180F
<b>STEP 3</b>	
Press for second part of Cycle 1: 	1 START) TT END) HL
<b>STEP 4</b>	
Press to move to next record: 	2 ON) 9:35 OFF) 20:42 175F
<b>STEP 5</b>	
Press and hold to exit and return to Status Screen 	

Using the data in the History Menu may help technicians identify system issues or changes in operation.

**Recommendation:** When using the data from the History Menu to help troubleshoot, record it using the chart provided on the next page.

Charting the cycles will make it easier to spot patterns or irregularities in the operation of the system.

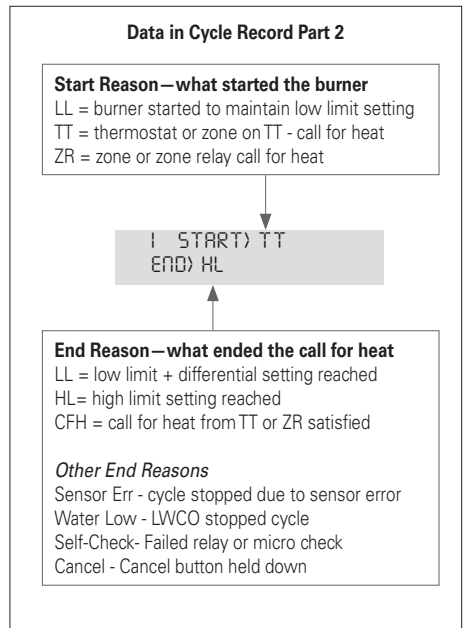
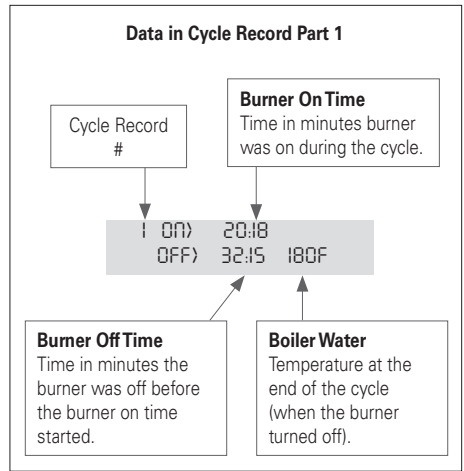

**Record History Here**

<b>Cycle 1 is most recent</b>	<b>On Time</b>	<b>Off Time Before Burner On</b>	<b>Temp at End of Call for Heat</b>	<b>Start Reason</b>	<b>End Reason</b>
Example 1	20:18	32:15	180F	TT	HL
Example 2	9:35	20:42	175F	ZR	CFH
Example 3	12:32	114.58	160F	LL	LL

<b>Cycle 1 is most recent</b>	<b>On Time</b>	<b>Off Time Before Burner On</b>	<b>Temp at End of Call for Heat</b>	<b>Start Reason</b>	<b>End Reason</b>
1					
2					
3					
4					
5					
6					
7					
8					
9					

# Final Checklist

## Before Leaving the Installation Site, Verify:

- All wiring has been done correctly in a professional manner, is secure and meets all applicable codes.
- 7610 control temperature settings, differentials and optional functions are correctly set.
- The control program is functioning properly by observing at least one complete cycle.
- At shutdown, the temperature and pressure level match the recommended settings.
- The pressure relief valve operation and boiler water feed system works properly by bleeding some water and observing the refill cycle.
- The low water cutoff operation by lowering the water level until it shuts the burner off.
- The boiler passages and vent system are clear of obstructions and operating to the appliance manufacturer's specifications and all required clearance dimensions to combustible materials are met.
- With combustion test instruments the burner is set to manufacturer's specifications.
- After the system has run through a complete cycle, that all fittings are free of leaks.
- A record has been made of all service work and all temperature control settings and optional functions. Attach a label or tag to the boiler for future reference.
- The 7610 Installation Manual is left at a suitable location near the boiler for future reference and the equipment owner is informed of this.
- The control door is attached and securely closed.

# Service

## During Annual Maintenance or More Frequent Service Intervals, Verify the below items.

**Note:** The 7610 control has no serviceable internal parts. DO NOT attempt to repair a malfunctioning control.

- The control is clean and all vents are free of dust, lint or foreign material.
- All wiring is tight, terminals are free from corrosion and insulation is intact.
- There is no physical damage to the case or display.
- There is no evidence of water damage on the control or terminals.
- The control is securely mounted to the well or other mounting support.
- The sensor is fully seated in the well.
- The sensor lead on remote mounted units is in good condition and securely anchored in the immersion well with the strain relief.
- The control temperatures, differentials and optional functions are set correctly and working to established specifications. Consult the service tag or label on the boiler.
- A record of service and any adjustments are made to the service label or tag.
- The control door is attached and securely closed.

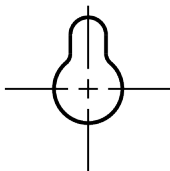

**THIS END UP**

## **Mounting Template**

Use self-drilling screws supplied in the  
Remote Mount Kit

-or-

Drill 0.110" diameter holes

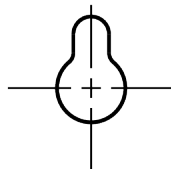
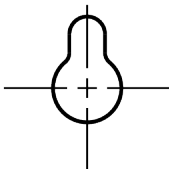

**Figure 21 – 7610A/B single-zone connections with or without a tankless coil**

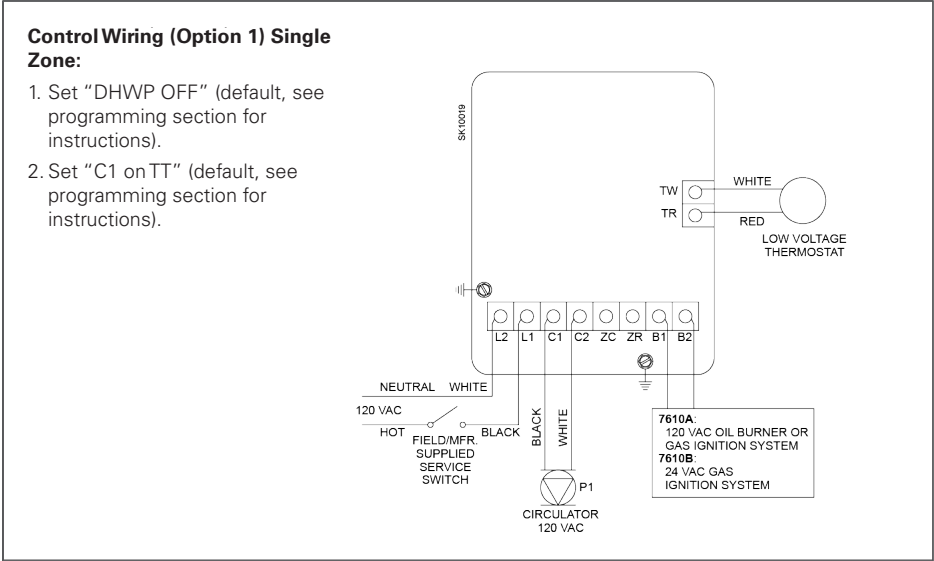

**Figure 22 – 7610A/B multi-zone connections with or without a tankless coil**

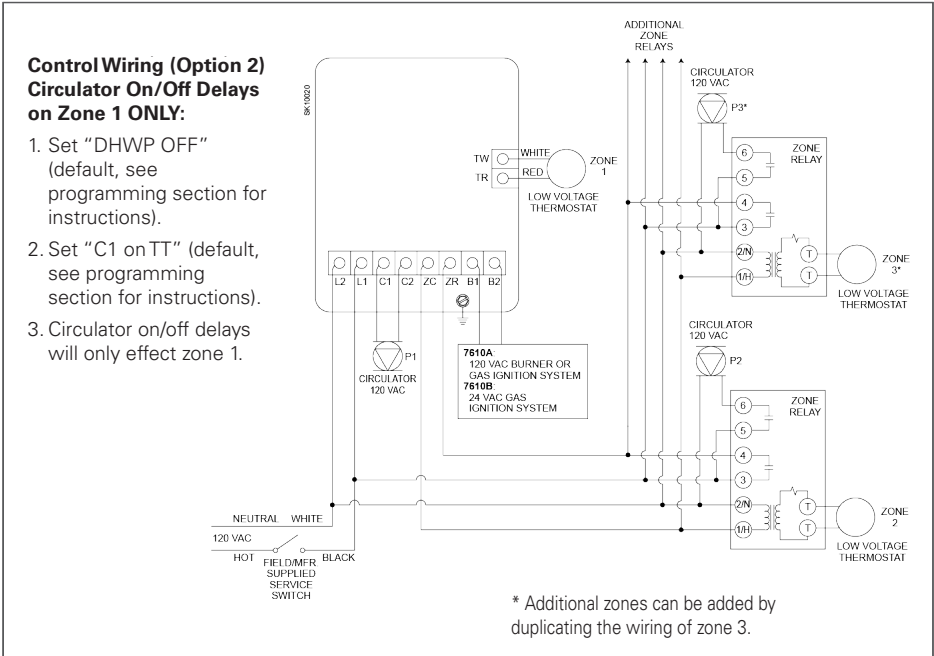



**Figure 23 – 7610A/B alternate multi-zone connections with or without a tankless coil**

\* Additional zones can be added by duplicating the wiring of zone 3, adding additional transformers as needed.

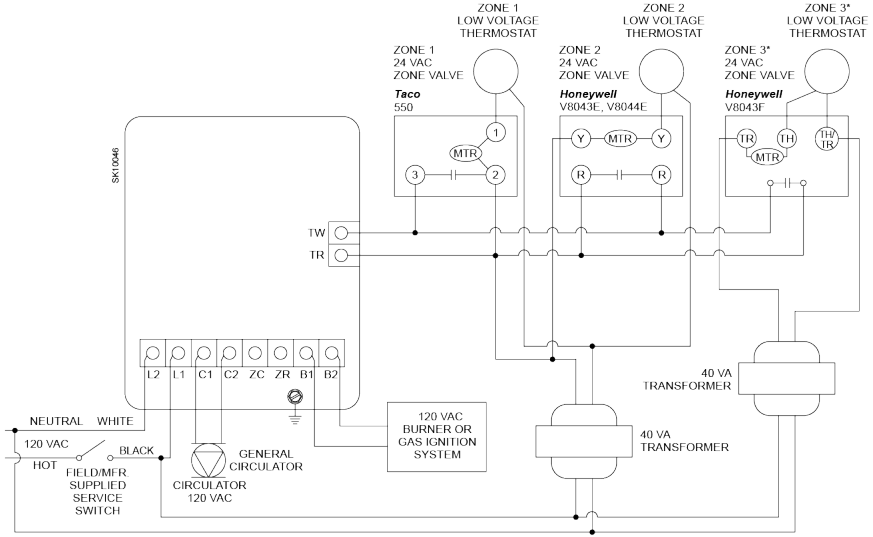

**Control Wiring (Option 3): 7610A with zone valves**

**CAUTION** - Always observe proper polarity when connecting multiple transformers in a system (connect red terminal of external transformer to TR terminal of 7610).

1. Set "DHWP OFF" (default, see programming section for instructions)
2. Set "C1 on TT" (default, see programming section for instructions)
3. Circulator-on delay will affect all zones. Circulator-off delay will have no effect.
4. 24 VAC zone valves cannot be powered directly with the 7610A. Add an additional transformer for every two or less valves.
5. Ensure there are no jumpers between the terminals of the zone valves.

**Figure 24 – 7610A/B multi-zone connections with Indirect Domestic Hot Water (DHW)**

\* Additional zones can be added by duplicating the wiring of zone 3.

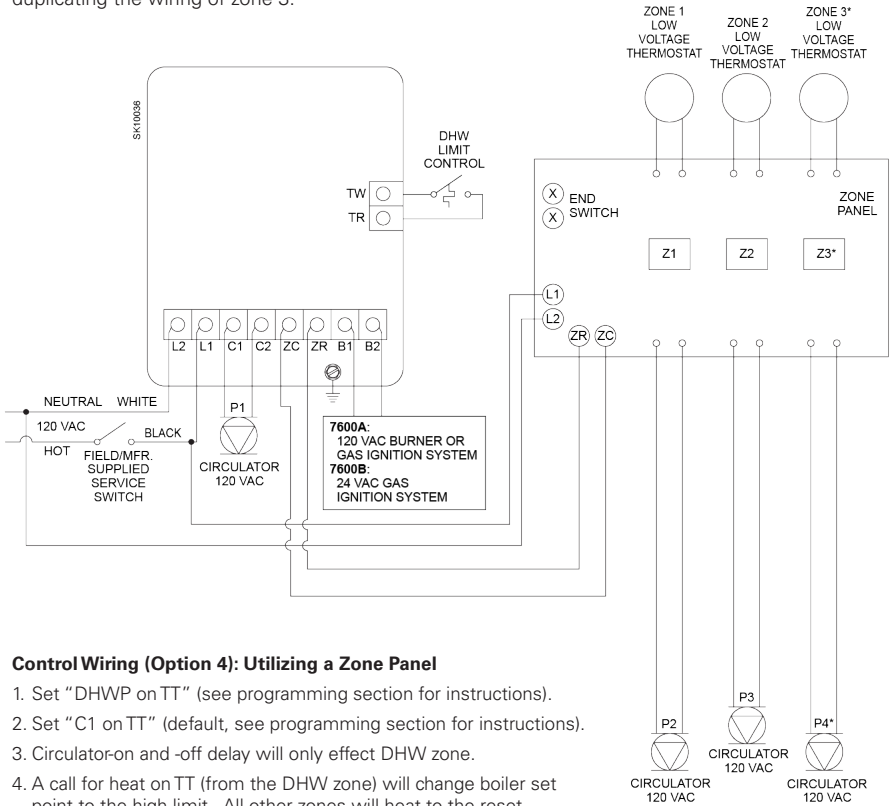

**Control Wiring (Option 4): Utilizing a Zone Panel**

1. Set "DHWP on TT" (see programming section for instructions).
2. Set "C1 on TT" (default, see programming section for instructions).
3. Circulator-on and -off delay will only effect DHW zone.
4. A call for heat on TT (from the DHW zone) will change boiler set point to the high limit. All other zones will heat to the reset temperature determined by the HeatManager.
5. Ensure that the zone panel and 7610 are powered from the same service switch.





## Limited Warranty Information

The R. W. BECKETT CORPORATION ("Beckett") warrants to persons who purchase its "Products" from Beckett for resale, or for incorporation into a product for resale ("Customers"), that its equipment is free from defects in material and workmanship. To qualify for warranty benefits, products must be installed by a qualified service agency in full compliance with all codes and authorities having jurisdiction, and used within the tolerances of Beckett's defined product specifications.

To review the complete warranty policy and duration of coverage for a specific product, or obtain a written copy of warranty form 61545, please choose one of the following options:

Visit our website at: [www.beckettcorp.com/warranty](http://www.beckettcorp.com/warranty)

Email your request to: [rwb-customer-service@beckettcorp.com](mailto:rwb-customer-service@beckettcorp.com)

Write to: R. W. Beckett Corporation, P. O. Box 1289, Elyria, OH 44036

**NOTE: Beckett is not responsible for any labor cost for removal and replacement of equipment.**

THIS WARRANTY IS LIMITED TO THE PRECISE TERMS SET FORTH ABOVE, AND PROVIDES EXCLUSIVE REMEDIES EXPRESSLY IN LIEU OF ALL OTHER REMEDIES, AND IN PARTICULAR THERE SHALL BE EXCLUDED THE IMPLIED WARRANTIES OF MERCHANTABILITY AND FITNESS FOR A PARTICULAR PURPOSE. IN NO EVENT WILL BECKETT BE LIABLE FOR ANY INCIDENTAL OR CONSEQUENTIAL DAMAGE OF ANY NATURE. Beckett neither assumes, nor authorizes any person to assume for Beckett, any other liability or obligation in connection with the sale of this equipment. Beckett's liability and Customer's exclusive remedy is limited to the cost of the product.

USA: **R.W. Beckett Corporation**, 1-800-645-2876  
Canada: **R.W. Beckett Canada Ltd**, 1-800-665-6972  
[www.beckettcorp.com](http://www.beckettcorp.com)

Printed in the USA 3/22 Form No. 62091 R02

This document and all information contained herein are the sole property of the R.W. Beckett Corporation and cannot be reproduced or transmitted in whole or part without express written permission of the R.W. Beckett Corporation.



**Beckett**<sup>®</sup>